

THIS DOCUMENT IS THE PROPERTY OF SELECT CONTROLS INCORPORATED AND IS CONVEYED WITH THE EXPRESS CONDITION THAT IT AND THE INFORMATION CONTAINED IN IT ARE NOT TO BE USED, DISCLOSED, OR REPRODUCED IN WHOLE OR IN PART, FOR ANY PURPOSE WITHOUT THE EXPRESS WRITTEN CONSENT OF SELECT CONTROLS INCORPORATED; AND THAT NO RIGHT IS GRANTED TO DISCLOSE OR SO USE ANY INFORMATION CONTAINED IN SAID DOCUMENT.

NOTE:

1. SWITCH: PLANAR, NORMALLY OPEN, AUTOMATICALLY RESETTABLE
2. WEIGHT: 2 GRAMS MAXIMUM
3. CONTACTS: SPST, NORMALLY OPEN
4. CONTACT RESISTANCE: 500 OHMS MAXIMUM
5. CONTACT RATING: 150MA AT 28VDC
6. INSULATION RESISTANCE: 30 MEGOHMS MINIMUM AT 500VDC
7. OPERATING CHARACTERISTICS:
  - a) MUST CLOSE WHEN TILTED PAST 75° FROM VERTICAL POSITION
  - a) MUST OPEN WHEN RETURNED TO VERTICAL POSITION
8. TEMPERATURE RANGE:
  - a) OPERATING: -65°F TO +185°F
  - b) NON-OPERATING: -65°F TO +221°F
9. SWITCH SEAL: HERMETIC; LEAKAGE SHALL NOT EXCEED  $1 \times 10^{-6}$  SCCS He AT 1 ATM.
10. LEAD STRENGTH: 3 LBS. MINIMUM AXIAL PULL.

4008-1-000

REVISIONS				
ALT	DESCRIPTION	BY	CHK	ENG

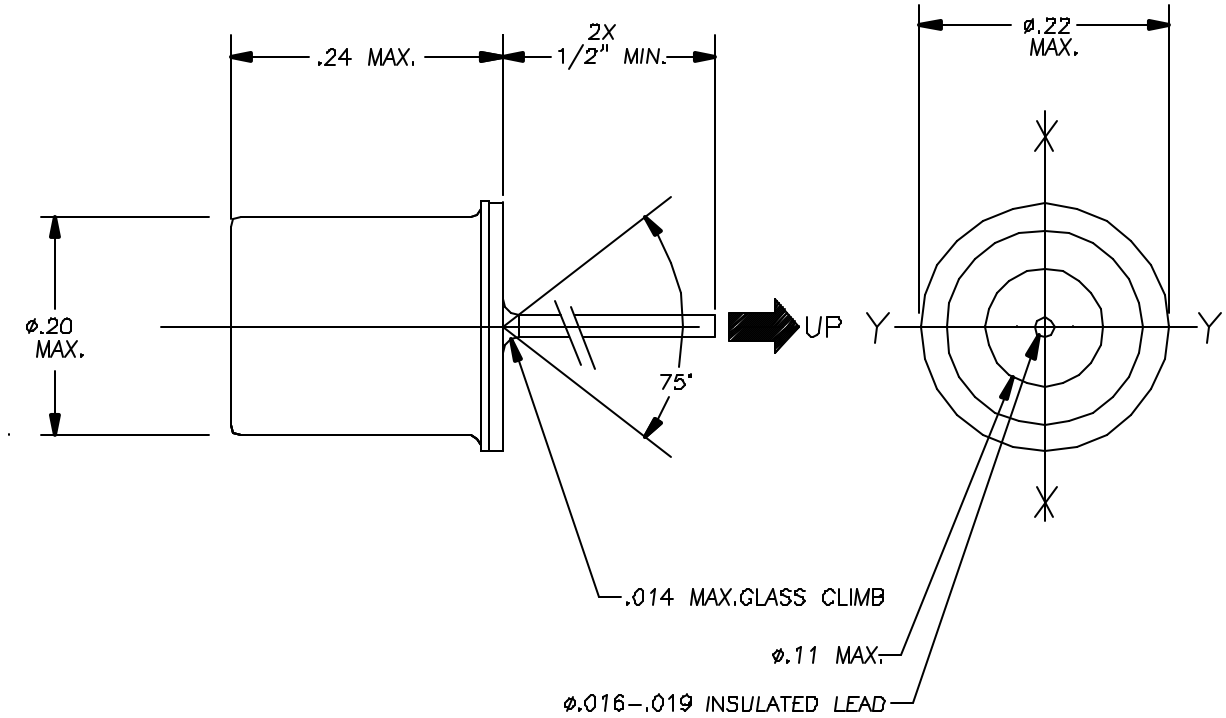

ITEM	NO. REQ'D	PART NO.	DESCRIPTION	REMARKS	
BILL OF MATERIAL					
MATERIAL		TITLE			
FINISH		SWITCH, MOTION/DISTURBANCE N.O., CASE GROUND			
DO NOT SCALE DRAWING REMOVE BURRS, BREAK SHARP EDGES TOLERANCES UNLESS SPECIFIED: FRACT: ±1/64 ANGLE ±0.20° MACH FINISH 125/ RFB DEC: .00 ±.010 DEC: .000 ±.005		NO. REQ'D	N/A	NO. REQ'D	N/A
		SCALE:	10:1	DESIGN: AHN	
		WEIGHT:	NOTED	DATE: 3/10/07	
		DRAWING NO.		REV	
		4008-1-000			
		DATE		SHEET 1 OF 1	

**S**elect Controls Inc. 45-3 KNICKERBOCKER AVE.  
BOHEMIA, N.Y. 11716