

THIS DOCUMENT IS THE PROPERTY OF SELECT CONTROLS INCORPORATED AND IS CONVEYED WITH THE EXPRESS CONDITION THAT IT AND THE INFORMATION CONTAINED IN IT ARE NOT TO BE USED, DISCLOSED, OR REPRODUCED IN WHOLE OR IN PART, FOR ANY PURPOSE WITHOUT THE EXPRESS WRITTEN CONSENT OF SELECT CONTROLS INCORPORATED; AND THAT NO RIGHT IS GRANTED TO DISCLOSE OR SO USE ANY INFORMATION CONTAINED IN SAID DOCUMENT.

NOTE:

1. SWITCH: UNIDIRECTIONAL, NORMALLY OPEN, AUTOMATICALLY RESETTABLE
2. WEIGHT: 2 GRAMS MAXIMUM
3. CONTACTS: SPST, NORMALLY OPEN
4. CONTACT RESISTANCE: 50 OHMS MAXIMUM
5. CONTACT RATING: 50MA AT 12VDC
6. INSULATION RESISTANCE: 30 MEGOHMS MINIMUM AT 500VDC
7. OPERATING CHARACTERISTICS: (A)
 - a) CONTACTS SHALL BE OPEN AT STEADY STATE ACCELERATIONS OF 6.25 G'S OR LESS
 - b) CONTACTS SHALL BE CLOSED AT STEADY STATE ACCELERATIONS OF 9.25 G'S OR MORE
8. TEMPERATURE RANGE:
 - a) OPERATING: -40°C TO +150°C
 - b) NON-OPERATING: -54°C TO +200°C
9. SWITCH SEAL: HERMETIC; PER MIL-STD-750C, TEST CONDITION D
10. LEAD STRENGTH: 3 LBS. MINIMUM AXIAL PULL

3112-1-000

REVISIONS		BY	CHK	ENG
ALT	DESCRIPTION			
A	SEE ECN 3112-1-000A	AHN		
		12/28/16		

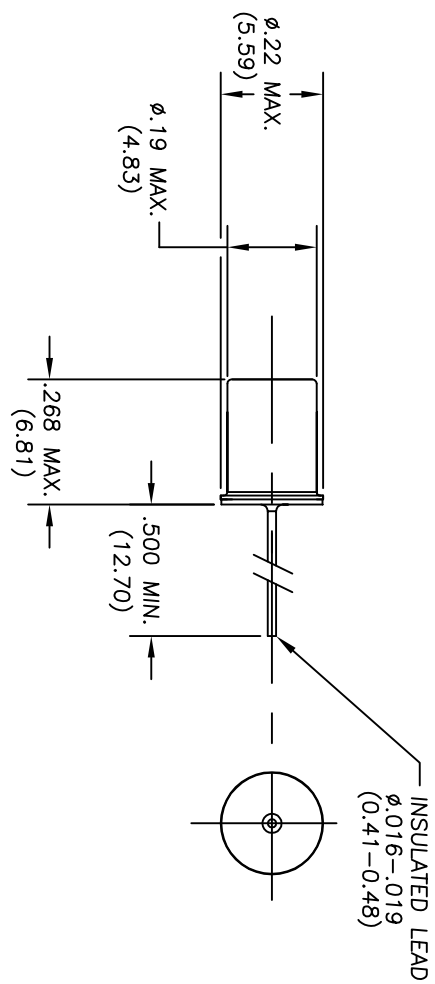

ACCELERATE THIS DIRECTION FOR CONTACT CLOSURE

(X.XX) DENOTES DIMENSIONS IN MILLIMETERS		NO. REV'D		PART NO.		BILL OF MATERIAL		DESCRIPTION		REMARKS	
MATERIAL		N/A		N/A		TITLE		AHN		45-3 KNICKERBOCKER AVE.	
FINISH		N/A		N/A		ACCELERATION SWITCH NORMALLY OPEN		select controls inc.		BOHEMIA, N.Y. 11716	
DO NOT SCALE DRAWING		SCALE: 4:1		WEIGHT: NOTED		DATE: 8/27/08		DRAWING NO. 3112-1-000		REV. A	
REMOVE BURNS, BREAK SWAGE EDGES. TOLERANCE UNLESS SPECIFIED: .005 ± .01		NO. REV'D		PART NO.		TITLE		DESCRIPTION		REMARKS	
MACH FINISH: 125		N/A		N/A		ACCELERATION SWITCH NORMALLY OPEN		select controls inc.		BOHEMIA, N.Y. 11716	
DEC: 200 3.005		NO. REV'D		PART NO.		TITLE		DESCRIPTION		REMARKS	
RHS		N/A		N/A		ACCELERATION SWITCH NORMALLY OPEN		select controls inc.		BOHEMIA, N.Y. 11716	